



2004 -

PEUGEOT 407 estate

Cat. No. **P/033**

e20

e20\*94/20\*0671\*00

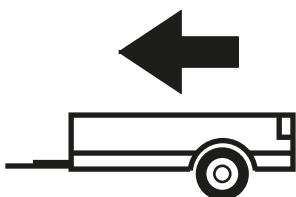

1600kg

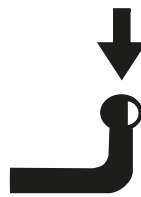

65kg

**D**=9,19kN

**D (kN) =**



MAX kg

x

MAX kg

x 0,00981



MAX kg

+

MAX kg

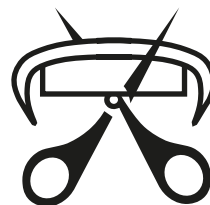
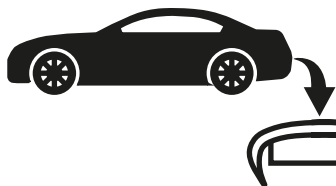

IMIOLA HAK-POL

96-111 KOWIESY, CHOJNATA 23A, POLAND

Tel. + 48 46 831 73 31, fax +48 831 74 29

e-mail: office@imiola.pl, www.imiola.pl



**PRZEKRÓJ A-A**

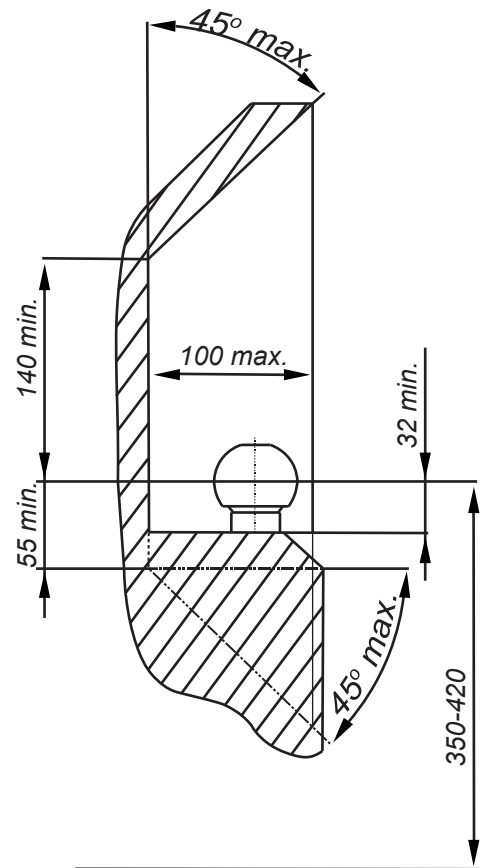

**PL** Należy zagwarantować przestrzeń swobodną według załącznika VII, rysunek 25a/b Regulaminu EKG ONZ 55.01 przy dopuszczalnym ciężarze całkowitym pojazdu.

**F** L'espace libre doit être garanti conformément à l'annexe VII, illustration de la réglementation 55.01 CE pour un poids total en charge autorisé du véhicule.

**GB** The clearance specified in appendix VII, diagram 25a/b of Regulation No. 55.01 UN EU must be guaranteed at laden weight of the vehicle.

**D** Der Freiraum nach Anhang VII, Abbildung 25a/b der Vorschriften 55.01 EG ist zu gew 25a/bahrleisten bei zulässigem Gesamtgewicht des Fahrzeuges.

Moment skręcący dla śrub i nakrętek (8.8) Torque settings for nuts and bolts (8.8)	
M8	25Nm
M10	55Nm
M12	85Nm
M14	135Nm
M16	195Nm



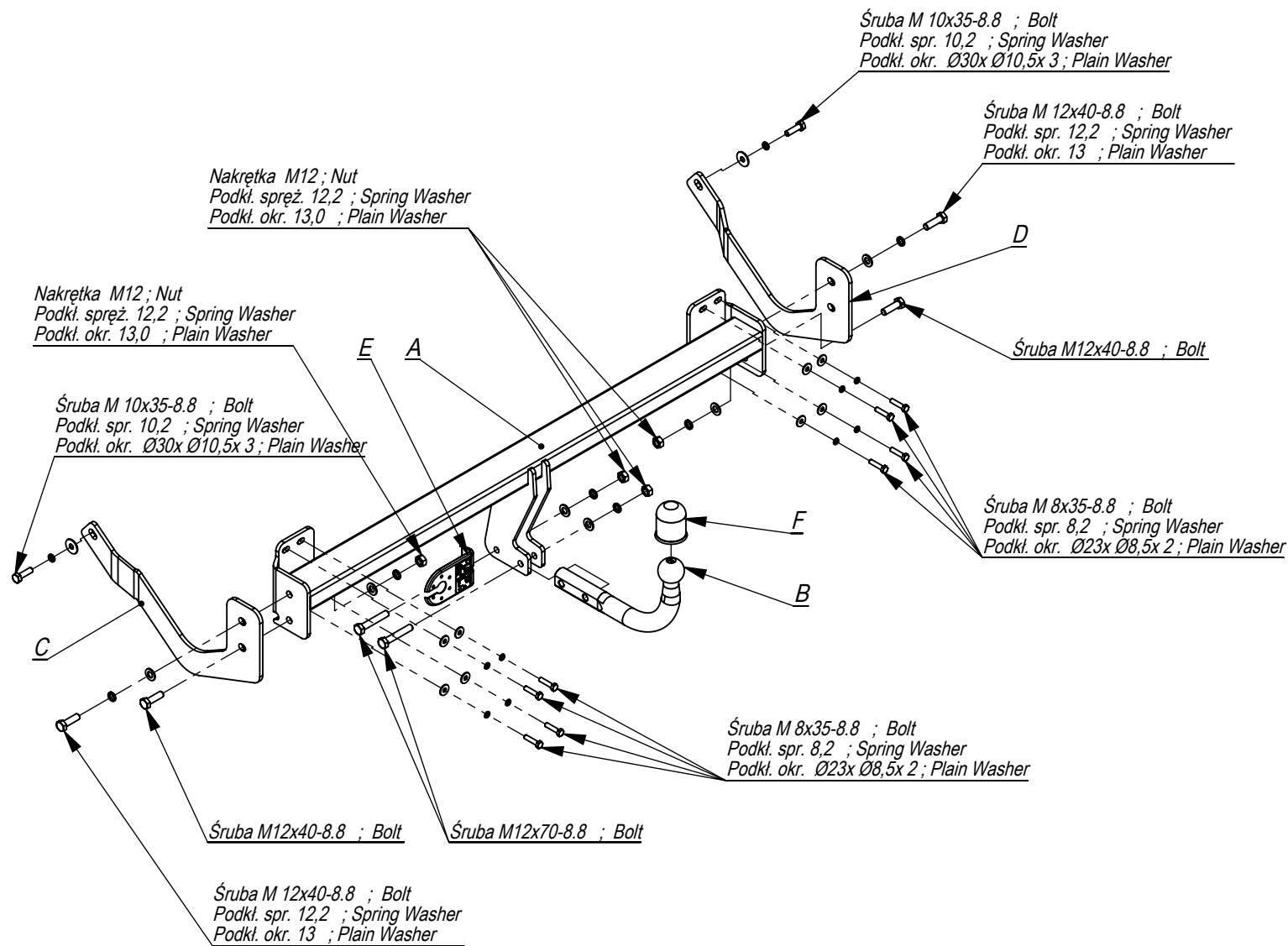

	A	x1		M12x70	2
				M12x40	4
				M10x35	2
				M8x35	8
	B	x1		M12	4
					Ø30xØ10,5x3
	C	x1		Ø23xØ8,5x2	8
					13
	D	x1		12,2	6
				10,2	2
				8,2	8
	E	x1			
	F	x1			

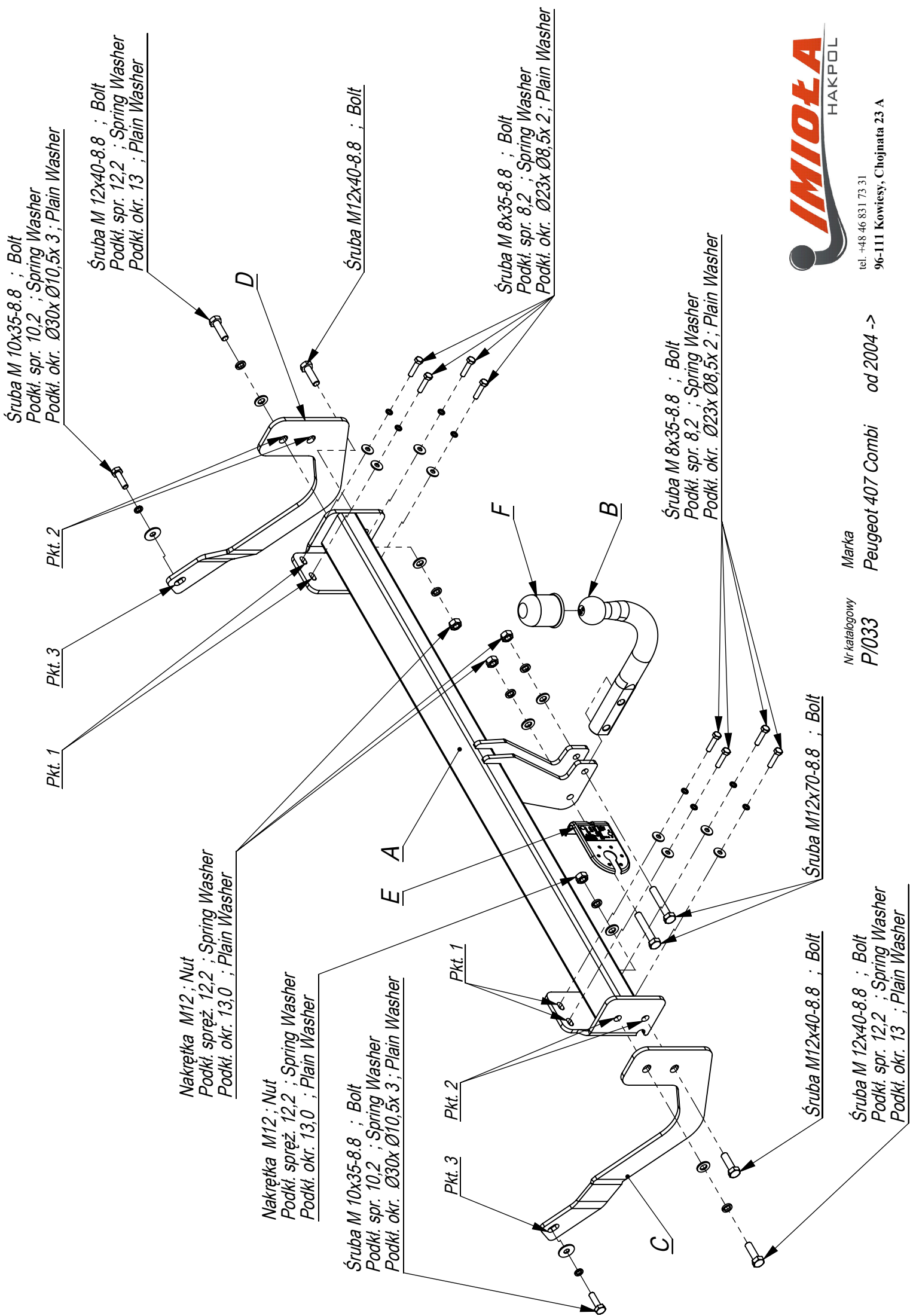

Śruba M 10x35-8.8 ; Bolt  
 Podkl. spr. 10,2 ; Spring Washer  
 Podkl. okr. Ø30x Ø10,5x 3 ; Plain Washer

Śruba M 12x40-8.8 ; Bolt  
 Podkl. spr. 12,2 ; Spring Washer  
 Podkl. okr. 13 ; Plain Washer

Śruba M12x40-8.8 ; Bolt

Śruba M 8x35-8.8 ; Bolt  
 Podkl. spr. 8,2 ; Spring Washer  
 Podkl. okr. Ø23x Ø8,5x 2 ; Plain Washer

Śruba M 8x35-8.8 ; Bolt  
 Podkl. spr. 8,2 ; Spring Washer  
 Podkl. okr. Ø23x Ø8,5x 2 ; Plain Washer

Śruba M12x70-8.8 ; Bolt

Śruba M12x40-8.8 ; Bolt

Śruba M 12x40-8.8 ; Bolt  
 Podkl. spr. 12,2 ; Spring Washer  
 Podkl. okr. 13 ; Plain Washer

Nakrętka M12 ; Nut  
 Podkl. spręż. 12,2 ; Spring Washer  
 Podkl. okr. 13,0 ; Plain Washer

Nakrętka M12 ; Nut  
 Podkl. spręż. 12,2 ; Spring Washer  
 Podkl. okr. 13,0 ; Plain Washer

Śruba M 10x35-8.8 ; Bolt  
 Podkl. spr. 10,2 ; Spring Washer  
 Podkl. okr. Ø30x Ø10,5x 3 ; Plain Washer

Nr katalogowy  
**P/033**

Marka  
**Peugeot 407 Combi**

tel. +48 46 831 73 31  
 96-111 Kowiesy, Chojnata 23 A



od 2004 ->

- Zdemontować tylne lampy.
- Odkręcić zderzak.
- Odkręcić plastikowe wzmocnienie zderzaka (nie będzie już wykorzystane).
- Przykręcić belkę haka A do tylnego pasa śrubami M8x35 8.8 (pkt 1).
- W każdej z podłużnic na zewnętrznej stronie odszukać i udrożyć technologiczne otwory (pkt 3)
- Elementy haka C i D przykręcić do belki haka A śrubami M12x35 8.8 (pkt 2) oraz do podłużnic śrubami M10x35 8.8 (pkt 3).
- Dokręcić wszystkie śruby z momentem wg tabeli.
- Podłączyć instalację elektryczną.
- Przykręcić zderzak.
- Przykręcić kulę i blachę gniazda elektrycznego.

- Disassemble the rear lights.
- Unscrew the bumper.
- Unscrew the plastic reinforcement of the bumper (it will not be used any more).
- Screw the main bar A to the rear belt with bolts M12x35 8.8 (point 1).
- Find the technological blind holes on the outsides of the metal clamps (point 3). Make them permeable.
- Screw the elements C and D to the main bar A with bolts M12x35 8.8 (point 2) and to the metal clamps with bolts M10x35 8.8 (point 3).
- Tighten all the bolts according to the torque setting- see the table.
- Connect the electric wires.
- Screw the bumper.
- Assemble the rear lights.
- Fix the ball and electric plate.

- Déposer les phares arriere.
- Serrer le pare-chocs. Dévisser le renfort en plastique de pare-chocs.
- Ne sera plus utilisé
- Serrer la traverse de corchet A a la partie arriere avec les boulons M8x35 8.8 (point 1).
- Retrouver et déboucher les ouvertures (point 2) dans chaque longeron, coté extérieure.
- Visser les éléments du crochet C et D a la traverse du crochet A par le boulons M12x35 8.8 (point 3) et aux longerons par les boulons M10x35 8.8 (point 2).
- Serrer tous les boulons avec un couple de serrage selon tableau.
- Raccorder le circuit électrique.
- Fixer un pare-chocs.
- Visser la boule et tôle de la prise électrique.

- Die hinteren Leuchten demontieren. Die Verstärkung abschrauben.
- Die Stoßstange abschrauben.
- Die Plastik Verstärkung der Stoßstange abschrauben, wird nicht wieder benutzt.
- Den Querbalken A an den hinteren Karosseriestreifen mit den Schrauben M8x35 8.8 anschrauben.
- In jedem Längsträger, auf der Außenseite die vom Werk aus vorhandenen Öffnungen finden und durchstehen (Punkt 3).
- Die Tragteile C und D an den Querbalken A mit den Schrauben M12x35 8.8 (Punkt 2) und an die Längsträger mit den Schrauben M10x35 8.8 (Punkt 3) anschrauben.
- Alle Schrauben mit dem in der Tabelle angegebenen Drehmoment festziehen.
- Die Elektroinstallation anschließen.
- Die Stoßstange anschrauben.
- Die Kugel und die Steckdosenhalterung mit anschrauben.

- Desenrosque el parachoques y las lámparas.
- Desenrosque la barra de impacto (ya no es necesario).
- Limpiar los orificios en los largueros.
- Fijar la barra del gancho a la correa trasera con tornillos M8x35 (punto 1).
- Fijar los elementos C y D a los largueros con tornillos M10x35 (punto 3) y a la barra del gancho A con tornillos M12x35 8.8 (punto 2).
- Apretar todos los tornillos con el par según la tabla anterior.
- Fijar el parachoques y las lámparas.
- Atornille la bola y la placa de toma de corriente eléctrica. con tornillos M12x70 8.8.
- Conectar la instalación eléctrica.

