

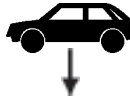

Opel Frontera
Opel Frontera Sport



1999 →



Type : 022581

2480 kg

112 kg

Montagehandleiding
Fitting instruction
Anbauanweisung
Description de montage
Instrucciones de montaje
Montagevejledning
Monteringsvejledning
Monteringshandleiding
Asennusohje
Návod k montáži



EC 94/20

e4 00-1109



2800 kg

D

waarde
value
Wert
valeur

12,90 kN

(c) Bosal 12-07-2006

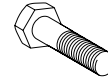

2x M12x1.25x70 (10.9)
5x M12x1.25x35
1x M12x1.25x90



3x M12 Ø30x13x6
6x M12



5x M12x1.25 (kl.10)



3x M12

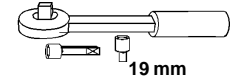
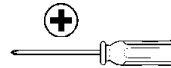

19 mm

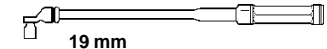

19 mm

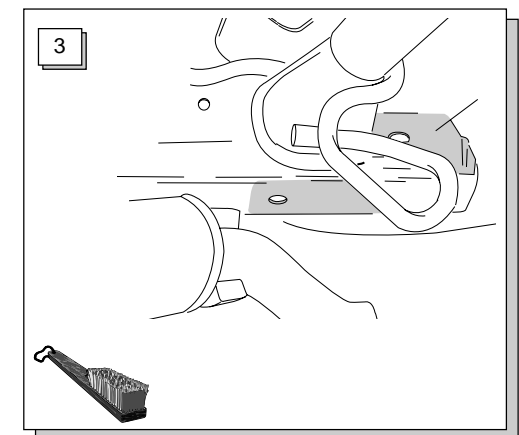
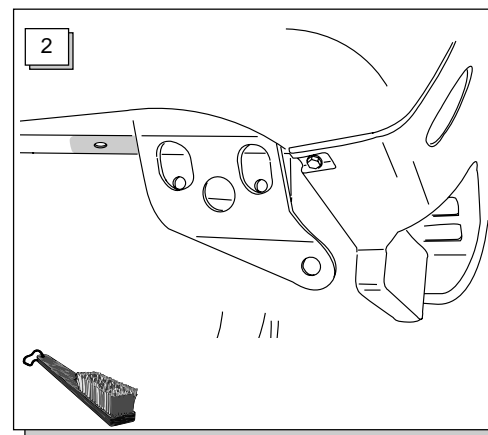
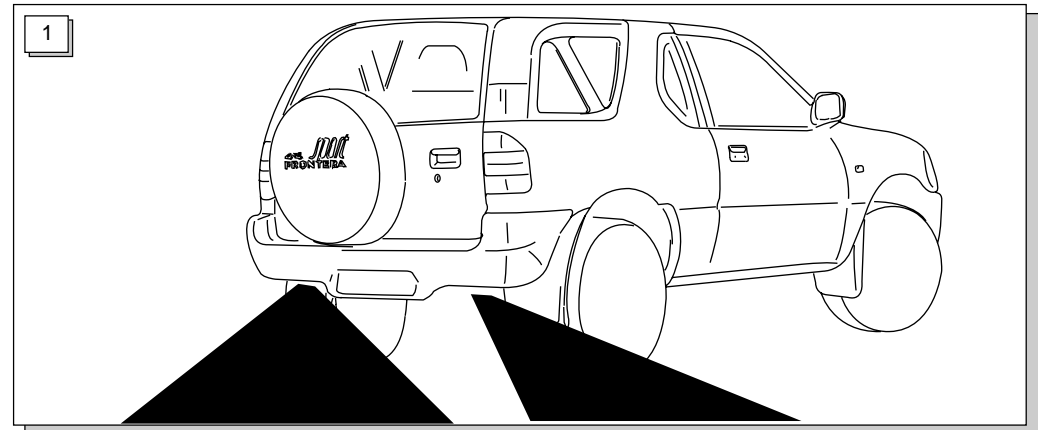
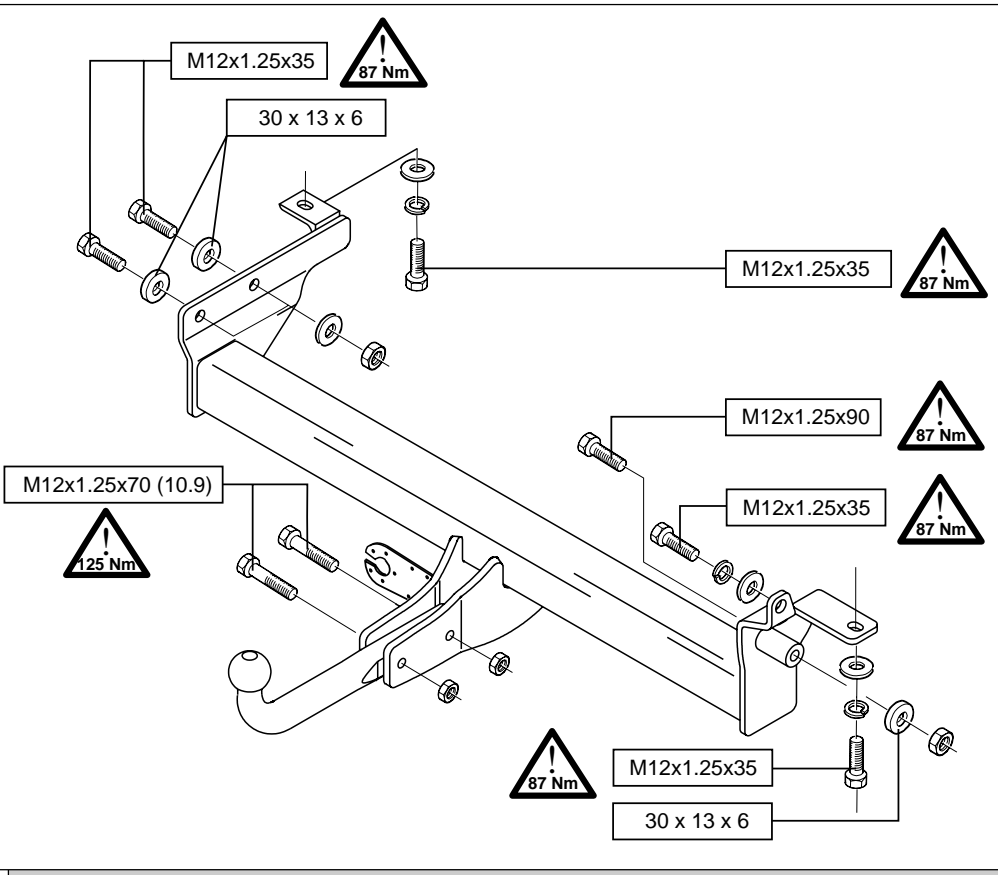

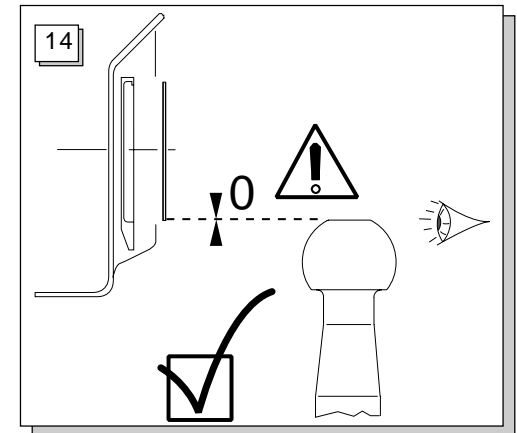
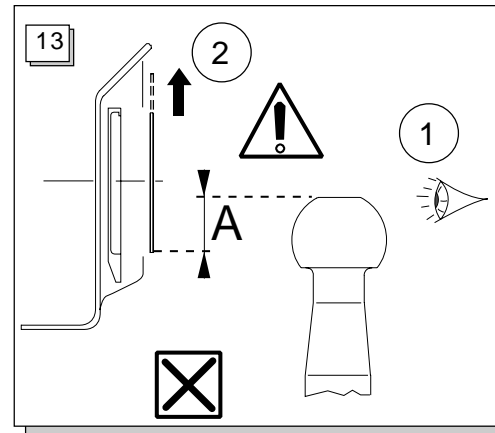
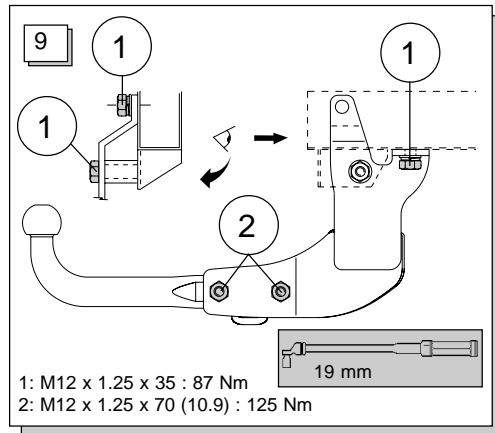
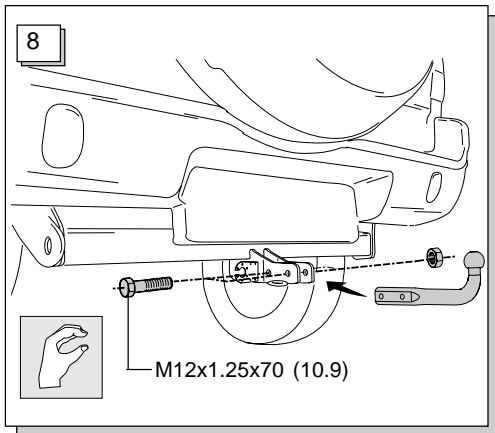
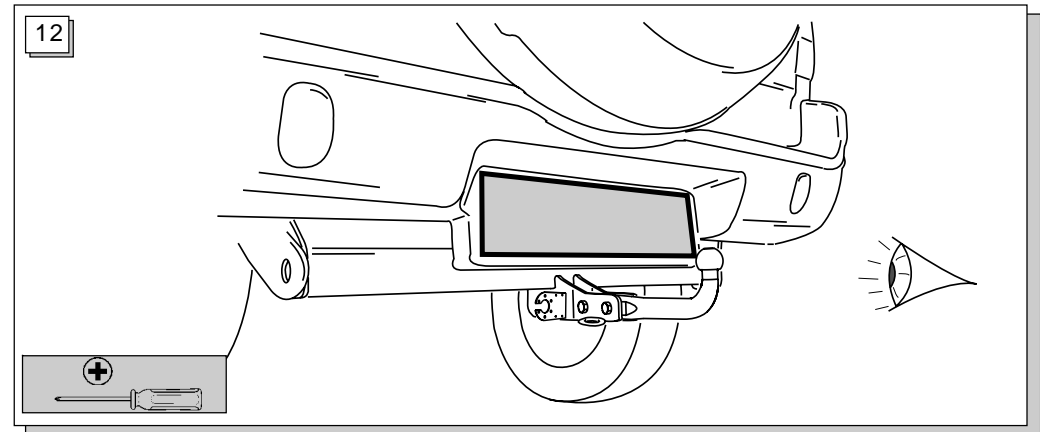
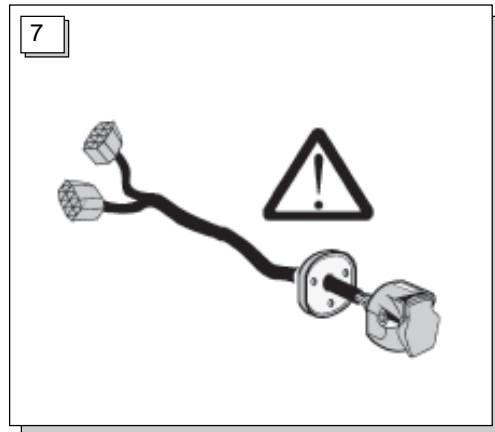
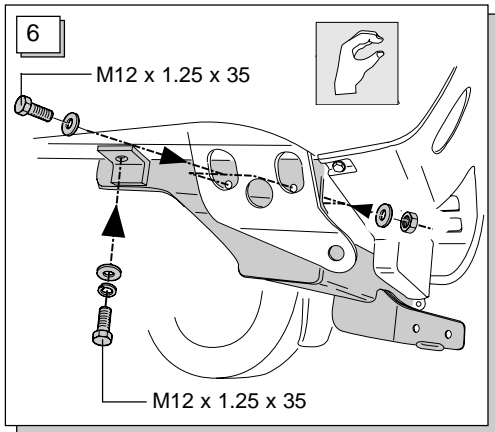
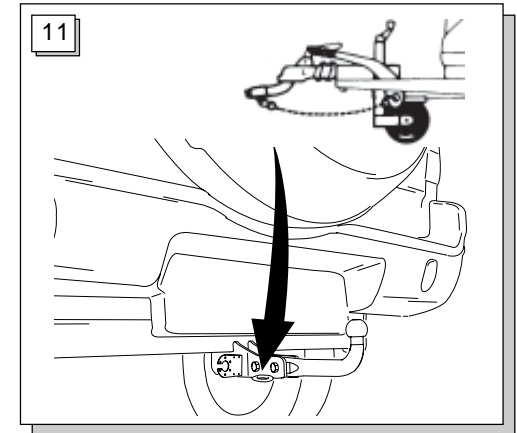
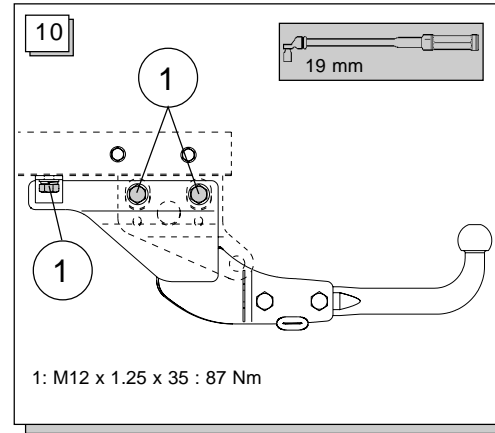
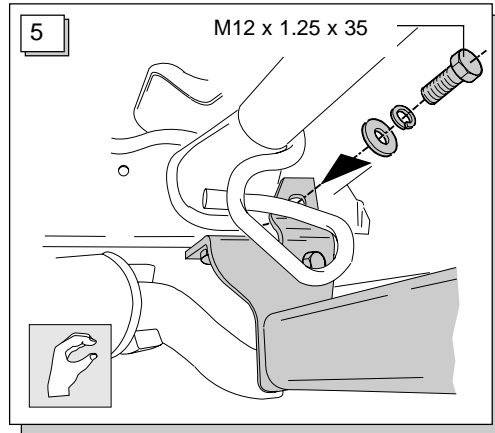
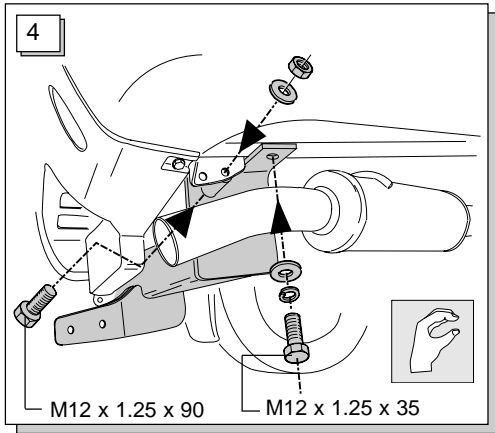

15



16

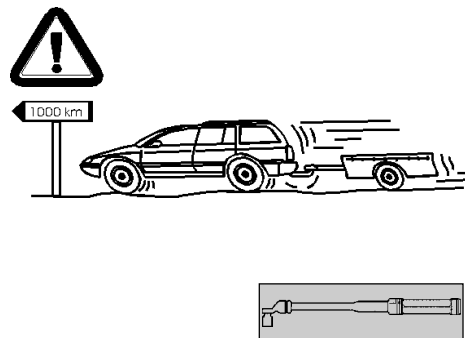

Notes :

Bosal kan niet aansprakelijk worden gesteld voor enig gebrek in het produkt zoals veroorzaakt door de schuld of door welk onoordeelkundig gebruik ook van de gebruiker of een persoon voor wie hij aansprakelijk is (art. 185, lid 2 N.B.W.).

Bosal cannot be held responsible for any defects in the product caused by fault or by any injudicious use whatever of the user or a person he is liable for. (sect. 185, art. 2 N.B.W.)

Für einen Mangel am Produkt, der durch den Fahrzeughalter oder eine andere Person aufgrund unsachgemäßer Benutzung verursacht wurde, übernimmt Bosal keine Haftung. (art. 185 lid 2 N.B.W.)

Bosal décline toute responsabilité concernant des défauts éventuels de cet attelage qui seraient causés par une mauvaise utilisation. Seul l'utilisateur est responsable (art 185 lid 2 NBW).

Bosal no asume responsabilidad de ningún tipo por defectos en el producto causados por o debidos a un uso imprudente, tanto por parte del usuario como de cualquier persona bajo su responsabilidad (art. 185, párrafo 2 N.B.W. (Código Civil Holandés)).

Bosal kan ikke gøres ansvarlig for mangler ved produktet, der er opstået som følge af skyld eller ukyndig anvendelse af brugeren eller en person som han er ansvarlig for (§ 185, stk. 2 N.B.W. (hollandsk privatret)).

Bosal kan ikke stilles ansvarlig for noen mangel ved produktet som kan forårsakes av skjødesløs eller ukyndig bruk. Ansvaret er brukerens eget (paragraf 185, ledd 2 i den nederlandske sivilrettslige lovboken).

Bosal kan inte ställas till ansvar för fel på produkten som orsakats av användaren eller genom omdömeslöst bruk av produkten av användaren eller en person som han bär ansvar för (art. 185, paragraf 2 i den nederländska civilrättsbalken).

Bosal ei ole vastuussa vahingoista, jotka ovat aiheutuneet käyttäjän virheestä tai tuotteen väärinkäytöstä (artikla 185 kohta 2 NBW).

Firma Bosal nenese zodpovednost za jakoukoliv závadu na výrobku způsobenou nesprávným zacházením ze strany uživatele nebo další zodpovědné osoby.

Raadpleeg uw dealer voor de max. massa die uw wagen mag trekken.

For the max. trailer weight of your car please refer to the owner's manual or your car homologation documents.

Die maximale Anhängelast ihres Fahrzeuges können Sie im Fahrzeugschein oder im Benutzerhandbuch nachlesen.

Pour connaître le poids maxi remorquable pour votre voiture consulter la notice d'utilisation de votre voiture ou la carte grise.

Consulte a su distribuidor sobre el peso máximo que puede remolcar su vehículo.

Deres forhandler vil kunne oplyse Dem om den højst tilladte vægt efter Deres køretøj.

Ta kontakt med forhandleren angående den maksimale vekt som bilen kan trekke.

Se handboken eller registreringsbevis för max släpvningsvikt för din bil.

Tarkista suurin sallittu vetopaino ajoneuvon ohjekirjasta tai rekisteriotteesta.

Maximální přípustná hmotnost přívěsu pro Vaše vozidlo je uvedena v technickém průkazu nebo v uživatelské příručce.